

ROUND PROFILES

TECHNICAL SPECIFICATIONS

ADROIT.

YOUR PROJECT. YOUR WAY. BE ADROIT.

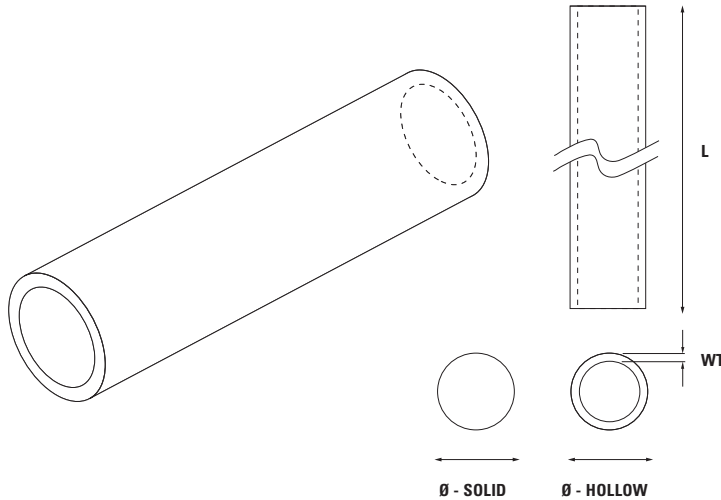

PRIMARY APPLICATION

EcoTuff™ profiles are an alternative to both softwood and hardwood material. If you have used metal, concrete, or timber in your design you can easily substitute EcoTuff™ round profiles. Unlike the alternatives EcoTuff™ will not rot, rust, splinter or require maintenance. EcoTuff™ is a recycled plastic composite that is stronger than softwoods. Each kilogram of EcoTuff™ diverts 990grams of waste from landfill. Increase your ROI, safety and project longevity by substituting an EcoTuff™ profile.

D CHART

Profile Type (PT)	Diameter (mm)	Wall Thickness (mm)	Maximum Section Length (mm)	Weight (Kg/m)
CI040 <small>ECOTUFF ADROIT</small>	100	15	6000	4.2
C1050	125	18	2400	4.16
CI060 <small>ECOTUFF ADROIT</small>	140	18	6000	8.4
RS040	50	SOLID	6000	2
CI041 <small>ECOTUFF ADROIT</small>	100	n/a	6000	8.4
PP030	75	SOLID	3000	4.16
PP03H	75	SOLID	3000	4.16
PP050	100	SOLID	2400	7.3
PP070	150	SOLID	2400	13.3
PP090	200	SOLID	2400	23.3
PP03C	75/100	CLUB	3000	6.04

FEATURES

- No toxic treatments to leach into the environment or end users.
- Co-mingled material means timber performance with no warping or significant expansion & contraction.
- Won't rot so can be used totally submerged where required.
- EcoTuff™ is UV stabilized to ensure a longer lasting look for your project.
- Lighter weight than steel or concrete means easier installation with less people and equipment.
- Splinter free nature and lack of sharp edges reduces exposure to liability.
- 100% recycled post consumer waste feedstock means your decision is great for the environment.
- Extruded material so can be produced in most shapes, dimensions or lengths.

OPTIONS

- Available in a large range of standard sizes and lengths.
- We can mill profiles into bollards, posts with holes or just about any other option.

MODELS

Profile Type (PT) - PT XXX – To specify the size you want refer to the D Chart to choose a Profile Type and then build your specification code as shown.

ADROIT-**CI030**-4200-SC (example)

Section Length (SL) – Specify your section length in mm up to the maximum section length.

ADROIT – CI030-**4200**-SC (example)

Colour (CC)

SC - Charcoal Grey
 HG- Heritage Green
 IB - Blue
 TC- Terracotta

EcoTuff™ is only available in SC.

ADROIT – CI030-4200-**SC** (example)

ADROIT.
YOUR PROJECT. YOUR WAY. BE ADROIT.

Subject to terms & conditions.
Please contact Adroit for full terms & conditions on 1300 ADROIT

HOW TO SPECIFY

ADROIT | **PT - SL - CC**
 Manufacturer | Profile Type | Sectional Length | Colour

A-T10020