

STIRLING

TECHNICAL SPECIFICATIONS

ADROIT.

YOUR PROJECT. YOUR WAY. BE ADROIT.

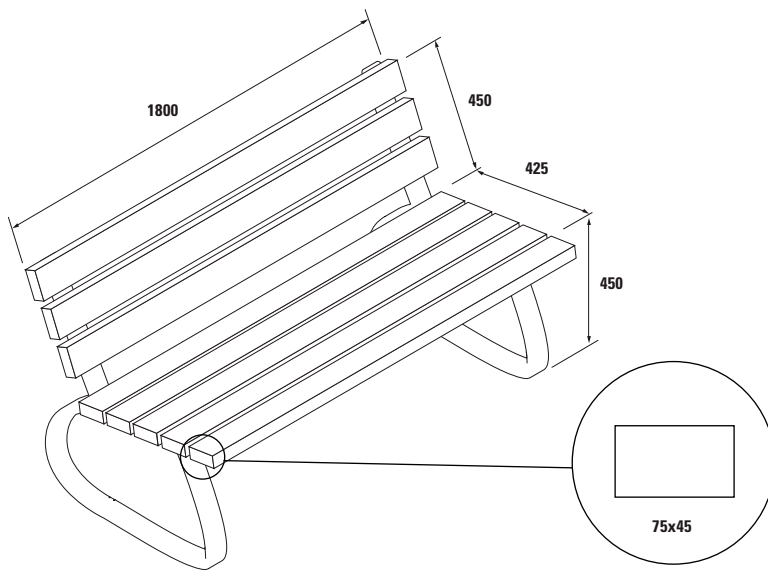

FEATURES

- Co-mingled bench & table slats will never rot rust or have dangerous splinters greatly reducing risk of injury to end users.
- Timber performance with no warping or significant expansion or contraction.
- High quality automated cutting and welding ensures the strongest possible frame hardened for use in high vandalism areas.
- Hot-Dipped Galv Bench Frame, the toughest of the tough, high quality dipped at 480degC so you don't have to worry about a rusting frame.
- UV stabilized bench & table slats to ensure a longer lasting look.
- 100% recycled post consumer waste feedstock for table & bench slats means your decision is great for the environment.
- Easily customisable.
- Standard is Standard Charcoal (SC) slats and galv dipped frame but slats are available in colours and frames can be powder coated any colour.

PRIMARY APPLICATION

The elegant yet funky design of the Stirling belies the hardened nature of its design and construction. For schools, skate parks and places where a combination of style and strength are required consider the Stirling. It's curved frame means fewer welds and joints making it incredibly strong. As with all our park furniture the refinement that has gone into perfecting the final product has happened over many years.

Suitable in just about any public situation the Stirling's formidable robustness comes from the quality build of a simple but tested design. In either full urban grey or specified in any number of frame and slat colours the Stirling will blend with and compliment any project.

OPTIONS

- Available in a massive range of colour combinations.
- Our customisation is easy and cost effective.

MODELS

Profile Type (PT) - CBF 3004 - To specify the bench and table slat colour you want refer to the instructions to build your specification code as shown. ADROIT-**CBF3002**-SC-FC (example)

Slat Colour (CC) - Specify SC for EcoTuff™ Standard Charcoal (SC). Or specify Heritage Green (HG), Blue (IB) or Terracotta (TC). ADROIT – CBF3002-**TC**-FC (example)

Frame Colour (CC) – Nominate Galv Dipped (GD) which is standard or a PMS colour e.g 246 or a word, e.g. Red ADROIT – CBF3002-TC-**GD** (example)