

# STEAMROLLER

## TECHNICAL SPECIFICATIONS

**ADROIT.**

YOUR PROJECT. YOUR WAY. BE ADROIT.

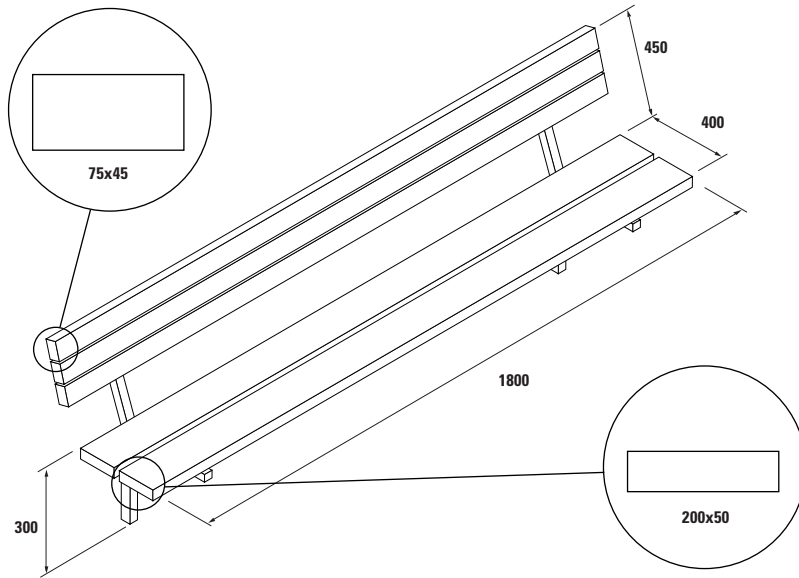

### PRIMARY APPLICATION

Named after the beautiful Steamroller Park in Stirling, South Australia the Steamroller is robust yet imbued with an understated elegance. To bring practicality and style to a high vandalism environment the Steamroller is an adroit choice. As with all our bench's the refinement that has gone into perfecting the final product has happened over many years.

Suitable in just about any public situation the Steamroller's formidable robustness comes from the quality build of a simple but tested design. In either full urban grey or specified in any number of frame and slat colours the Steamroller will blend with and compliment any project.

### FEATURES

- Co-mingled bench and table slats will never rot rust or have dangerous splinters greatly reducing risk of injury to end users.
- Co-mingled bench and table slat material means timber performance with no warping or significant expansion & contraction.
- High quality automated cutting and welding ensures the strongest possible frame hardened for use in high vandalism areas.
- Hot-Dipped Galv Bench Frame, the toughest of the tough, high quality dipped at 480degC so you don't have to worry about a rusting frame.
- UV stabilized bench and table slats to ensure a longer lasting look for your project.
- 100% recycled post consumer waste feedstock for table and bench slats means your decision is great for the environment.
- Easily customisable. Please contact us to discuss customising colour and size to your project
- Standard is Standard Charcoal (SC) slats and galv dipped frame but slats are available in colours and frames can be powder coated any colour.

### OPTIONS

- Available in a large range of standard sizes and lengths.
- Available in a massive range of colour combinations.
- Our customisation is easy and cost effective.
- Available in spigot or base plate model.

### MODELS

**Profile Type (PT)** – CBF 3001– To specify the bench and table slat colour you want refer to the instructions to build your specification code as shown.  
ADROIT-**CBF3001**-SC-FC (example)

**Slat Colour (SC)** – Specify SC for EcoTuff™ Standard Charcoal (SC). Or specify Heritage Green (HG), Blue (IB) or Terracotta (TC).  
ADROIT – CBF3001-**TC**-FC (example)

**Frame Colour (CC)** – Nominate Galv Dipped (GD) which is standard or a PMS colour e.g 246 or a word, e.g. Red.  
ADROIT – CBF3001-TC-**GD** (example)

**ADROIT.**  
YOUR PROJECT. YOUR WAY. BE ADROIT.

Subject to terms & conditions.  
Please contact Adroit for full terms  
& conditions on 1300 ADROIT

### HOW TO SPECIFY

**ADROIT**  
|  
Manufacturer

**PT - SC - FC**  
| | |  
Profile Slat Colour Frame  
Type Colour Colour

A-T10130